

# Chesapeake & Delaware LLC

## SYSTEM WIRE, CONDUIT AND CABLE STANDARDS

*Effective January 2, 2019*

## **Table of Contents**

Purpose.....	3
Definitions.....	4
Wire, Conduit and Cable Installation Process .....	5
Overview.....	5
Initial Discussion between Applicant and Railroad.....	5
Application.....	5
Field Survey .....	5
Development of a Site Plan.....	5
Development and Execution of a License Agreement.....	6
Performance of Construction Work .....	6
Final Inspection.....	6
Safety and Environmental Permitting.....	7
Safety .....	7
Environmental Permitting.....	7
Field Survey .....	8
Field Survey Overview .....	8
Railroad Track .....	8
Utilities.....	8
Structures .....	8
Control Points .....	9
Topography.....	9
Site Plans.....	10
General Site Plan Information .....	10
Specifications.....	11
Notice to Proceed.....	11
Wire, Conduit and Cable Construction Requirements.....	12
General Requirements.....	12
Safety Requirements .....	12
Longitudinal Occupations.....	14
Inductive Interference .....	15
Attachments .....	16

## **Purpose**

The primary purpose of these Chesapeake and Delaware System Wire, Conduit and Cable Standards (Standards) is to provide Applicants the necessary information to design and construct wires, conduits and cables across and along Chesapeake and Delaware, LLC (Railroad) Property.

These Standards shall also apply to other tracks over which Railroad operates its equipment.

It is to be clearly understood that the primary purpose of Railroad Property is to operate railroads. All occupancies shall, therefore, be designed and constructed so that rail operations and facilities are not interfered with, interrupted or endangered. In addition, the proposed Facility shall be located to minimize encumbrance to the Railroad Property so that Railroad shall have unrestricted use of its property for current and future operations.

Prior to the commencement of construction, a License Agreement must be executed between the Railroad and Applicant to address maintenance responsibilities, liability and indemnification.

The following pages in these Standards include specifications, requirements, and recommendations for the design and construction of wires, conduits and cables constructed across and along Railroad.

Notwithstanding any specifications contained herein, all materials and work shall meet all applicable AREA Engineering Requirements and Standards, as well as any local, state and federal regulations, guidelines and mandates.

**Note:** These Standards are subject to revision without notice.

## **Definitions**

**APPLICANT** – Individual, corporation or municipality desiring occupancy of Railroad Property.

**AREMA** – American Railway Engineering and Maintenance-of-Way Association.

**CARRIER PIPE** – Pipe used to transport Product.

**CASING PIPE** – The pipe through which the Carrier Pipe is installed.

**FACILITY/FACILITIES** – Conduit, Carrier Pipe, cables, fibers, junctions, repeaters, terminals, power sources, attachments, structures or shelters, and all other necessary and appurtenant articles of personal property connected with, necessary for or useful to the construction, installation, operation, maintenance, repair, reinstallation, replacement, relocation and removal of the aforementioned, as installed by Applicant.

**NOMINAL L-L VOLTAGE** – Line-To-Line voltage.

**OVERHEAD CLEARANCE** – The measured distance (in feet) from the top of the high rail to the bottom of sag of the bottom wire at 65° F.

**PROFESSIONAL ENGINEER** – Engineer licensed in the state where the Facilities are to be constructed.

**PRODUCT** – A substance produced during a natural, chemical, or manufacturing process.

**RAILROAD** – Chesapeake and Delaware, LLC, or any subsidiary company of Chesapeake and Delaware, LLC.

**RAILROAD PROPERTY** – Applies to any property owned, or operated under lease, by Railroad.

**RAILROAD PROJECT REPRESENTATIVE** – The Applicant's primary contact person for the Railroad as provided at the onset of a project.

**RIGHT OF WAY** – Where used on Attachments to these Standards denotes the limits of Railroad Property.

**“SHALL”** – Where the term “shall” appears in these Standards, it is to mean that the information following is a requirement.

**“SHOULD”** – Where the term “should” appears in these Standards, it is to mean that the information following is a recommendation.

## **Wire, Conduit and Cable Installation Process**

### **Overview**

The typical process for the installation of a new wire, conduit or cable, or the modification of an existing wire, conduit or cable, is:

1. Initial discussion between Applicant and Railroad
2. Application
3. Field survey
4. Development of a site plan
5. Development and execution of a License Agreement
6. Performance construction work
7. Final inspection

### **Initial Discussion between Applicant and Railroad**

Applicant and Railroad will discuss the project and the Applicant's needs.

### **Application**

Applicants desiring occupancy of Railroad Property must complete, and submit to Railroad, the required application. This should be done prior to conducting any field survey.

To obtain the application for wire, conduit or cable occupancy, please visit the following: [http://www.chesapeakeanddelaware.com/RealEstate\\_UtilityCrossings.html](http://www.chesapeakeanddelaware.com/RealEstate_UtilityCrossings.html)

**Note:** For longitudinal crossings, see “**Longitudinal Crossings**” for additional requirements.

### **Field Survey**

Applicants shall conduct a field survey to accurately identify railroad track, utilities, structures, control points and topography prior to developing a site plan. The survey shall be conducted in compliance with the Railroad's Right of Entry permitting requirements, to be advised by Railroad.

### **Development of a Site Plan**

Applicant shall develop a site plan and present the plan to Railroad. Unless otherwise approved by Railroad, the plan must adhere to the requirements of these Standards.

On extensive projects that are largely located off of Railroad Property, only those site plans involving work on, or affecting, Railroad Property and operations shall be

submitted. Included in such applications shall be a site plan showing the extent of the total project, upon which the portion of the project that affects Railroad is clearly defined.

Pre-plan and pre-construction site inspections for wire, conduit and cable crossings are not required unless, in the opinion of Railroad, the size and location of the Facility warrant an inspection.

### **Development and Execution of a License Agreement**

A License Agreement shall be executed between Applicant and Railroad to set forth the conditions regulating construction, liability, insurance, clearances, and other standard requirements of Railroad while clearly delineating the division of ownership and maintenance point(s) for the Applicant Facility. Following execution, and the demonstration of all required insurance, construction may proceed.

To obtain a sample standard License Agreement, please visit the following:  
[http://www.chesapeakeanddelaware.com/RealEstate\\_Documents.html](http://www.chesapeakeanddelaware.com/RealEstate_Documents.html)

### **Performance of Construction Work**

Applicant shall perform all construction work. All work must be performed in accordance with the approved site plan and by the terms of the License Agreement.

### **Final Inspection**

Applicant shall notify Railroad upon completion of all Applicant construction work. Railroad shall inspect the construction to verify compliance with the approved site plan and these Standards, and shall provide written notice of any defects.

## **Safety and Environmental Permitting**

### **Safety**

The Railroad's highest priority is the safety of its employees, customers and the communities served by the Railroad. **BEFORE** entering Railroad Property for any purpose—including scouting, surveying, staking out or inspecting—the Applicant shall obtain a Right of Entry Permit. While on Railroad Property, Applicant shall be responsible for adhering to Railroad requirements for worker protection, as deemed necessary by Railroad.

For more information on obtaining a Right of Entry Permit, please visit the following:  
[http://www.chesapeakeanddelaware.com/RealEstate\\_Access.html](http://www.chesapeakeanddelaware.com/RealEstate_Access.html)

It is to be clearly understood that the issuance of an entry permit **DOES NOT** constitute authority to proceed with any construction. Construction shall not begin until a formal agreement is executed between Applicant and Railroad and the Applicant receives permission from Railroad to proceed with the work.

### **Environmental Permitting**

Applicant shall be responsible for all required environmental permitting and stormwater management planning for the project, including work on Railroad Property. If it is determined that wetland and/or stream delineation is required on Railroad Property for permit application(s), the Applicant *shall* contact the Railroad Project Representative *prior to the performance of the delineation*. Upon completion of any environmental field delineation, Applicant shall provide Railroad with copies of all data, notes, photographs, and/or other information related to the delineation and shall provide a copy of any draft report(s) prepared for submittal to any governmental entity, court, or third party prior to submittal for Railroad review and comment. Applicant shall maintain all information regarding such information as confidential except as required for the purpose of obtaining permit(s).

## **Field Survey**

### **Field Survey Overview**

An accurate field survey is of utmost importance for the development and approval of an acceptable site plan. In particular, the following five categories are important elements of Applicant surveys:

1. Railroad track
2. Utilities
3. Structures
4. Control points
5. Topography

### **Railroad Track**

Proper depiction of the railroad track is essential to developing a workable design on the site plan. The following items shall be located and shown on site plans:

1. Centerline of existing tracks at top of rail
2. Nearest milepost and direction of increasing mileposts

### **Utilities**

Utilities must be accurately depicted on site plans, as missed utilities can drastically alter a project. The following utility items shall be located and shown on the drawings:

1. Aerial utility and light poles, guy wires, and guy poles
2. Natural gas line (valves, markers, and/or vents)
3. Telephone or fiber optic lines (junction boxes, or markers)
4. Water lines (taps, valves, meters, markers)
5. Sewer lines (taps, cleanouts, manholes, markers)
6. Storm water (inlets, outfalls, catch basins, manholes)

Overhead wires should be surveyed for their elevation at the point at which they cross any existing tracks, if applicable. Their location and elevation should also be determined at the point of their greatest sag and referenced to the corresponding existing ground elevation along with an additional point at the centerline of all tracks.

### **Structures**

Structures, existing and / or proposed, have the potential to adversely impact clearances and feasibility. The following items shall be shown on the site plan with clearances measures to the centerline of track:



1. Doorways, sides and top
2. Corners of docks and finished floor elevations
3. Fences and gates
4. Unloading pits and scales, inside and outside walls
5. Corners/sides of buildings and finished floor elevations
6. Roadways
7. Retention pond levees and drainage structures
8. Retaining walls
9. Utility poles for side clearances
10. Overhead and under grade bridges
11. Signals and signal structures including AEI tag readers, hot box detectors, dragging equipment detectors, pedestals, signal pole lines, and bungalows
12. Other structures that might impact clearances

### **Control Points**

All control points established or found during the course of the field survey shall be shown and labeled with description (PK nail, iron pin, survey monument, etc.) and NEZ coordinates based on the controlling datum. The controlling datum shall be identified in the corresponding NAD83, NGVD88 state plane coordinate system for the project site, allowing the Railroad to incorporate the project into the pertinent GIS database.

Real estate information, such as property pins or corners, should also be collected and shown on the plans.

### **Topography**

Although the Railroad does not typically require submittal of complete grading plans, the collection of adequate ground shots to accurately depict the nature of the ground topography and drainage features is important. Large or sudden changes in ground topography adjacent to proposed Facility must be measured and noted.

## Site Plans

### **General Site Plan Information**

Plans for proposed wire, conduit and cable occupancies shall be submitted to and approved by Railroad prior to Railroad issuance of a License Agreement, and prior to the start of construction.

Site plans shall be drawn to scale and shall include the pertinent Railroad Track, Utilities, Structures, Control Points and Topography information outlined in “**Field Survey**” of these Standards (also reference the attached *CAD Plan “Clearance Wire”* and *CAD Plan “Plates I”* through *CAD Plan “Plate IV”*).

Additional details must be shown on the site plan as follows:

1. All known property lines and Railroad Property lines.
2. If wires, cable or conduits are within public highway limits, such limits shall be clearly indicated with dimensions shown from centerline of road to centerline of proposed poles. (See *CAD Plan “Plate I”*).
3. Base diameter, height, class and bury of poles.
  - a. Note: Poles shall be set as close to the Railroad Property line as possible and in no instance closer than 18’-0” from face of pole to centerline of nearest track. When necessary, however, each location shall be analyzed to consider speed, traffic, etc.
4. The angle of the crossing in relation to the centerline of the tracks(s).
5. Number of size and material of power wires, as well as number of pairs in communication cables.
6. Nominal voltage of line.
7. Location, number of, size of, material or anchors and all guying for poles and arms.
  - a. Note: Double cross-arms are required on poles adjacent to track. Any tower or steel pole foundation design must be accompanied by engineering computations and data stamped by a Professional Engineer. Any tower or steel pole to be installed on Railroad Property must meet or exceed the industry standards regarding design and usage.
8. Profile of ground on centerline of pole or tower line, showing clearances between top of high rail and bottom of sag, as well as clearances from bottom wire or cable to top wire or cable of Railroad’s transmission, signal and communication lines when present. If Railroad facilities listed above do not exist at the point of crossing, the plan shall so state. Actual vertical clearance shall be shown.
  - a. Note 1: The minimum clearance between the top wire of any Railroad pole line and any proposed overhead guy wire shall not be less than 4’ – 0”.

- b. Note 2: The minimum clearance from crossing gate tips, cantilever structures, signal masts, signal and other bridges, etc. shall conform to the National Electrical Safety Code, section 23, rule 234, but in no case shall the overhead clearance in these Standards be reduced.

In all cases, the name of the State and County in which the proposed Facility is located shall be shown. In States where Townships, Ranges and Sections are used, plans shall show the distance in feet to the nearest Section line and identify the Section number, Township and Range.

All site plans shall include a preliminary timeline for the performance of all work required to construct the Facility described on the plan.

Once the site plan has been approved by Railroad, no variance from the site plans, specifications, method of installation, construction, etc., as approved in the License Agreement, will be considered or permitted without the payment to Railroad of additional fees for the re-processing of the application.

All site plans and computations associated with the work under the agreement shall be prepared by, and bear the seal of, a Professional Engineer. If not so imprinted, the application will be given no further consideration. This requirement also applies to all data submitted by any contractor of the Applicant.

## **Specifications**

Project specifications, for all work on and affecting Railroad Property, shall be included with the submission. All pertinent requirements of this document shall be included.

## **Notice to Proceed**

After approval of the site plans and specifications, the execution of the License Agreement, and the payment of all required fees, the Applicant will received a notice to proceed from Railroad. The Railroad will then coordinate all construction aspects of the project that relate to Railroad.

Railroad must be notified a minimum of fourteen (14) working days prior to desired start of construction.

## **Wire, Conduit and Cable Construction Requirements**

### **General Requirements**

Overhead power and communication lines shall be constructed in accordance with the National Electrical Safety Code (current edition), Part 2, “Safety Rules for the Installation and Maintenance of Overhead Electric Supply and Communication Lines”, except as otherwise outlined in these Standards.

All underground installations carrying power or communication wires and cables shall be constructed and properly marked with signs, in accordance with *Chesapeake and Delaware System Pipeline Standards*, current edition.

Under special conditions, Railroad will give consideration to occupations on its structures, subject to the approval of Railroad.

### **Safety Requirements**

All operations shall be conducted so as not to interfere with, interrupt, or endanger the operation of trains, nor damage, destroy, or endanger the integrity of Railroad Property.

All work on or near Railroad Property shall be conducted in accordance with Railroad safety rules and regulations. The contractor shall secure and comply with the Railroad safety rules and shall give written acknowledgement to Railroad that they have been received, read, and understood by the contractor and its employees.

Work on or near Railroad Property may also require worker protection. For additional information on worker protection requirements, please visit:

[http://www.chesapeakeanddelaware.com/RealEstate\\_RWP.html](http://www.chesapeakeanddelaware.com/RealEstate_RWP.html)

Construction operations will be subject to Railroad inspection at any and all times.

All cranes, lifts, or other equipment that will be operated in the vicinity of Railroad electrification and power transmission facilities shall be electrically grounded as directed by Railroad.

At all times when the work is being progressed, a field supervisor for the work with no less than twelve (12) months experience in the operation of the equipment being used shall be present. If boring equipment or similar machines are being used, the machine operator also shall have no less than twelve (12) months experience in the operation of the equipment being used.

Whenever equipment or personnel are working closer than 15 feet (4.6m) from the centerline of any track, that track shall be considered as being obstructed. Insofar as possible, all operations shall be conducted no less than this distance. Operations closer than 15 feet (4.6) from the centerline of a track shall be conducted only with the

*Chesapeake and Delaware System Wire, Conduit and Cable Standards*

permission of, and as directed by, a duly qualified Railroad employee present at the site of the work, or as specifically authorized by Railroad.

Crossing of tracks at grade by equipment and personnel is prohibited except by prior arrangement with, and as directed by, Railroad.

## **Longitudinal Occupations**

The following additional requirements apply to longitudinal occupations.

When submitting a site plan, the Applicant shall stake out key points along the proposed longitudinal occupation, such as crossings, alignment, radical changes in alignment, etc.

The site plan must show the location of all proposed poles, and must include the following information in addition to the detail of the pole top configuration as called for on Plate IV of these Standards:

1. Voltage of circuit(s) or number of pairs.
2. Phase of electrical circuit(s).
3. Number of electrical circuits.
4. Size (AWG or CM) and material of wires or cables.
5. Length of spans clearly indicated on drawing.
6. Any intended future wires or cables.

Wires and cables running longitudinally along Railroad Property shall be constructed as close to property lines as possible.

After receiving the site plan, Railroad will make arrangements for a site investigation, during which the proposed occupation will be field checked to insure compliance with and conformance to these Standards. At that time, comments, recommendations, changes to, or approval of, all locations will be made.

Any Facilities overhanging Railroad property must have approval of the Railroad, must confirm to these Standards, and are subject to the appropriate rental charges.

## **Inductive Interference**

An inductive interference coordination study is required for all proposed longitudinal occupations. This study may also be required for any crossing other than 90° with the track(s).

All agreements covering crossings and longitudinal occupations shall include provisions that the Applicant provide appropriate remedies, at its own expense, to correct any inductive interference with Railroad facilities.

## **Attachments**

Plan “Clearance Wire” – Clearance Requirements for Cable Crossings

Plan “Plate I” – Information for Site Plans of Right of Way Crossings

Plan “Plate II” – Information for Cross Section Diagrams of Right of Way Crossings

Plan “Plate III” – Information for Site Plans of Longitudinal Crossings

Plan “Plate IV” – Information for Cross Section Diagrams of Longitudinal Crossings



## CLEARANCE REQUIREMENTS FOR CABLE AND WIRE CROSSINGS

Note: All power and communication lines constructed over, under or parallel to the railroad shall meet or exceed the requirements of the National Electric Safety Code, latest revision.

### OVERHEAD CLEARANCE

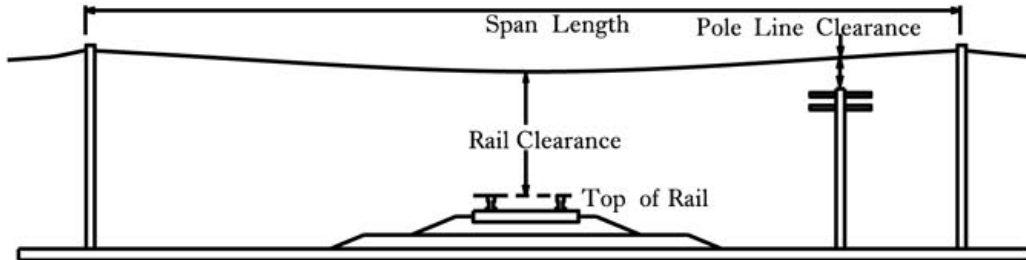

In no case shall crossings have less vertical clearance than the following at a final unloaded sag at 60 deg. Fahrenheit, or for span lengths greater than the standard span lengths for the appropriate geographic loading district, at the maximum conductor temperature for which the supply line is designed to operate.

Distance Above	Guys, Messenger And Comms Spans	Open Supply Line or any Neutral (phase to ground voltage)		
		0 to 750 V	750 V-15 kV	15 kV - 50 kV
Rail	27 Feet	30 Feet	31 Feet	33 Feet
Pole Line	2 Feet	2 Feet	4 Feet	6 Feet

• Add 1/2 Inch for each 1000 volts (phase to ground) above 50 kV

Loading District	Standard Span Lengths
Heavy	175 Feet
Medium	250 Feet
Light	350 Feet

Note - The applicant will furnish the design final sag data.

### UNDERGROUND CLEARANCE

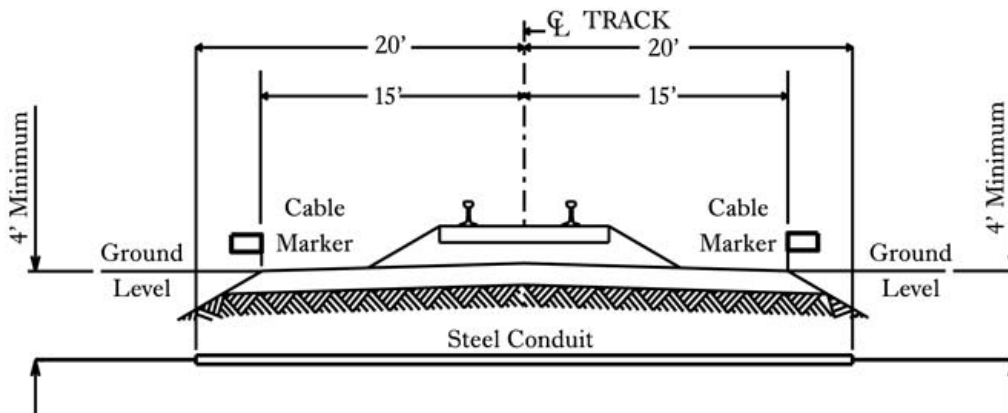

Power and communications underground wire and cable crossings must be buried a minimum 5 1/2 feet below base of rail and 4 feet below ground level for entire width of right-of-way and must be installed in steel conduit beneath the track, extending a minimum of 20 feet from the centerline of nearest track. Cable marker signs must be installed 15 feet from centerline of nearest track on both sides at points of right-of-way entry/exit. Signs must indicate cable owner, depth buried and voltage.

**INFORMATION TO BE SHOWN ON SITE PLAN VIEW OF DRAWINGS FOR RIGHT OF WAY CROSSINGS**

**Chesapeake & Delaware LLC**

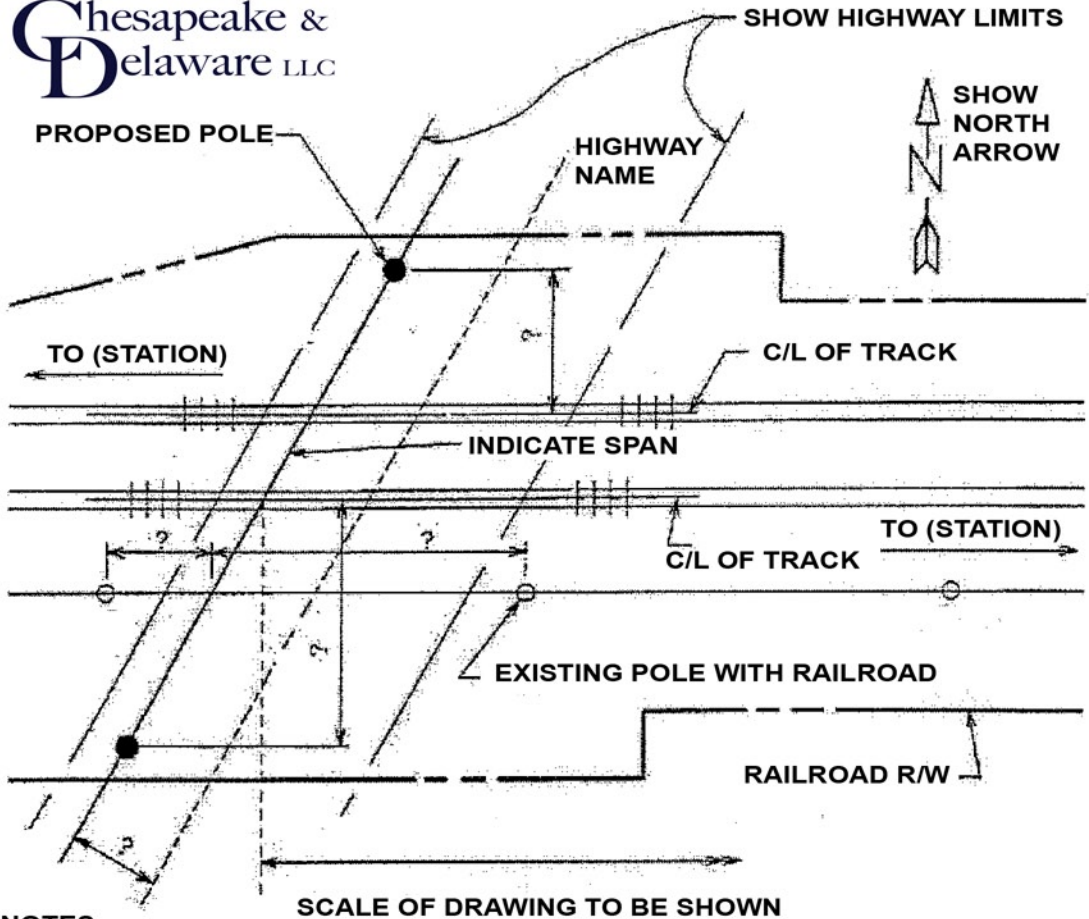

**NOTES:**

**IF THE PROPOSED LINE IS TO SERVE A NEW DEVELOPMENT, A MAP SHOWING THE AREA IN RELATION TO ESTABLISHED AREAS AND ROADS IS TO BE SENT WITH THE REQUEST.**

**IF THE PROPOSED LINE IS NOT WHOLLY (OR PARTIALLY) WITHIN HIGHWAY LIMITS, THE SAME INFORMATION IS REQUIRED AS SHOWN ON THIS PLATE.**

**LOCATE RAILROAD FACILITIES (SUCH AS CROSSTIES AND CANTILEVERS, FLASHERS, GATES, ETC) AND SHOW CLEARANCES FROM ALL**

**POLES SHALL BE LOCATED AS CLOSE TO THE RAILROAD RIGHT OF WAY LINE AS POSSIBLE**

**INFORMATION TO BE SHOWN ON CROSS SECTION  
OF DIAGRAMS WHEN FACILITY IS A CROSSING**

**PLAN: Plate II**

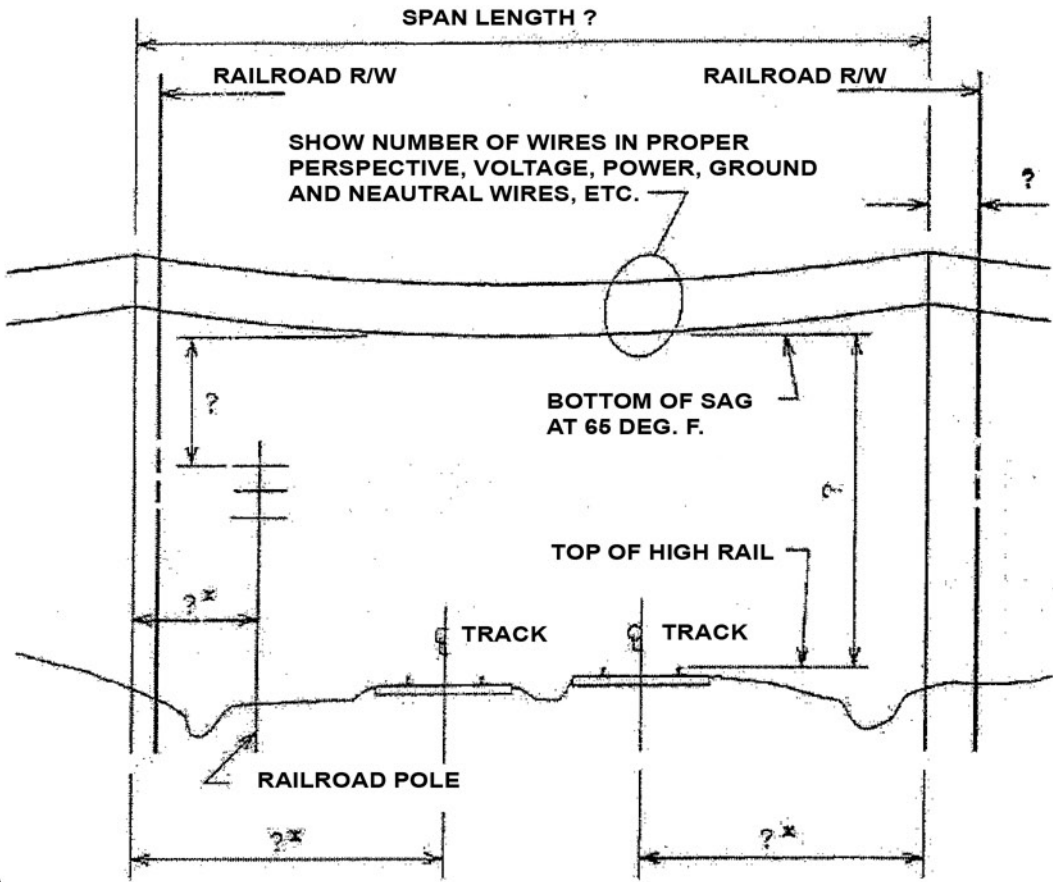

SECTION LOOKING \_\_\_\_\_ (DIRECTION)

SCALE: H \_\_\_\_\_  
V \_\_\_\_\_

MEASURED AT RIGHT ANGLES TO TRACK

NOTE 1: ALL TRANSMISSION, SIGNAL, COMMUNICATION LINES SHALL BE INDICATED AND PROPER CLEARANCES SHOWN.

NOTE 2: SHOW MAXIMUM SAG INCREASE OF POWER WIRES OVER TRACKS IF SPAN EXCEED 175 FEET IN LENGTH

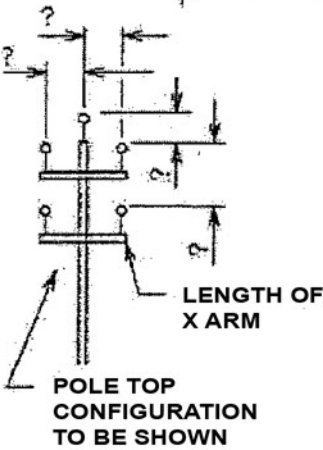



**INFORMATION TO BE SHOWN ON SITE PLAN VIEW OF DRAWINGS  
WHEN FACILITY IS A LONGITUDINAL CROSSING**

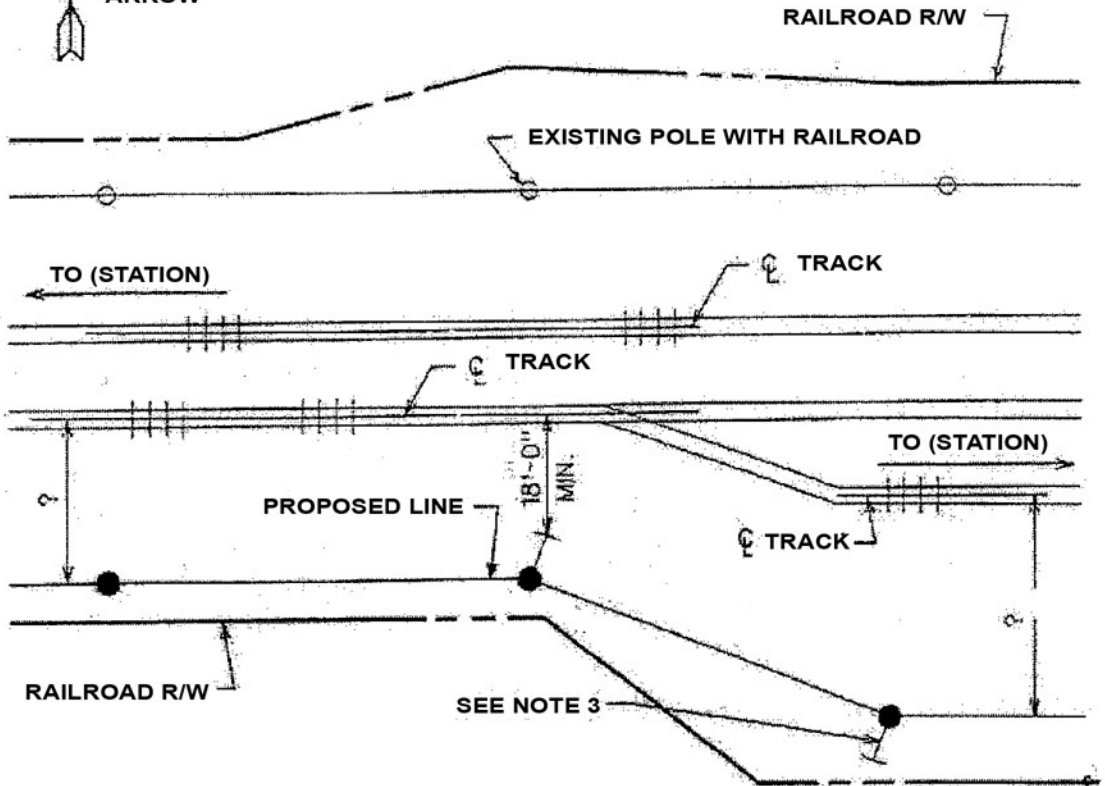

**SCALE OF DRAWING TO BE SHOWN**

**NOTE:**

- 1. EACH END OF THE LINE MUST SHOW MEASUREMENTS**
- 2. IF POWER LINE CROSSES ANY TRACK, THEN THE INFORMATION SHOWN ON PLATE IS ALSO REQUIRED**
- 3. WHERE ANCHOR GUYS ARE REQUIRED, THE MINIMUM CLERANCE MUST BE 18'-0" FROM FACE OF ANCHOR TO CENTERLINE OF NEAREST TRACK. CROSSING SECTIONS MUST BE SUBMITTED FOR ALL ANCHOR LOCATIONS.**
- 4. THE DISTANCE BETWEEN EACH POLE IS TO BE SHOWN.**
- 5. ASSIGNED POLE NUMBERS TO BE SHOWN AT EACH POLE.**



**INFORMATION TO BE SHOWN ON PROFILE SECTION OF DRAWINGS  
WHEN FACILITY IS A LONGITUDINAL OCCUPATION**

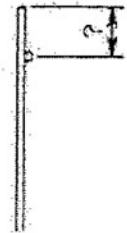
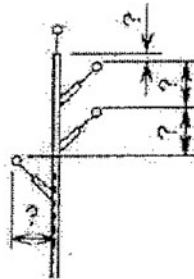
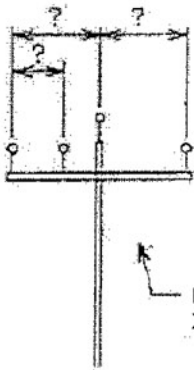
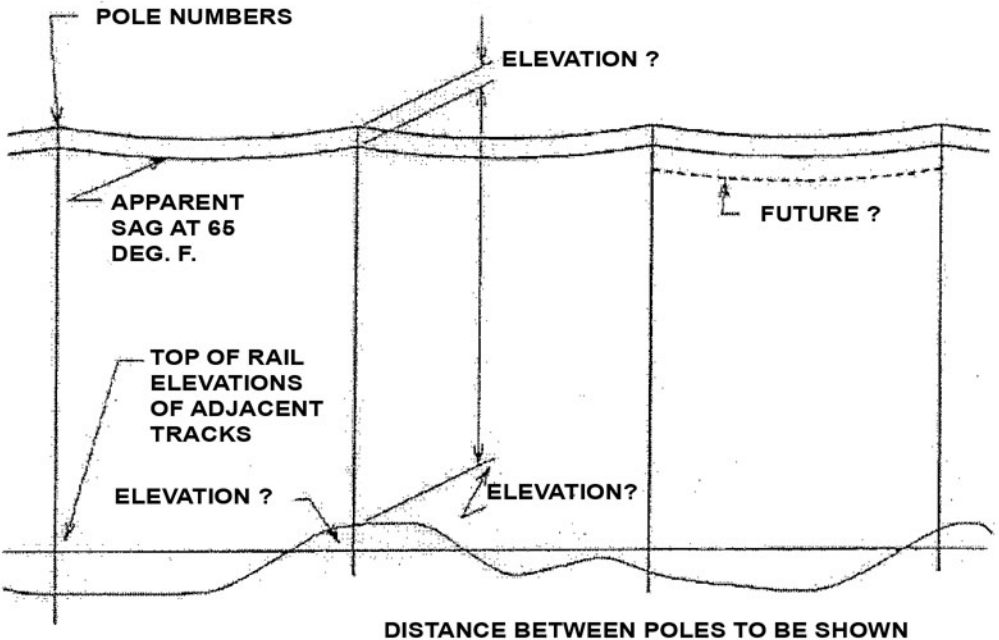

**Chesapeake &  
Delaware LLC**

**POLE TOP CONFIGURATION TO BE SHOWN SIMILAR TO SAMPLES ABOVE**

**NOTE: IF POWER LINE CROSSES ANY TRACK, THEN INFORMATION SHOWN ON  
PLATE II IS ALSO REQUIRED**